

Locomotive Data

Cylinders 18" Dia. x 24" Stroke

Driving Wheels 6' 2"

Leading Wheels 3' 8" Dia.

Gooch Valve Gear

Heating Surface

Tubes 1229 sq.ft.

Firebox 79 sq.ft.

Total 1308 sq.ft.

Area of Firegrate 13.8 sq.ft.

Locomotive Details

Progress No.	Road Number 'Class 197'
158	85 (later 87)
159	86 (later 88)
160	89
161	90
162	91
163	92

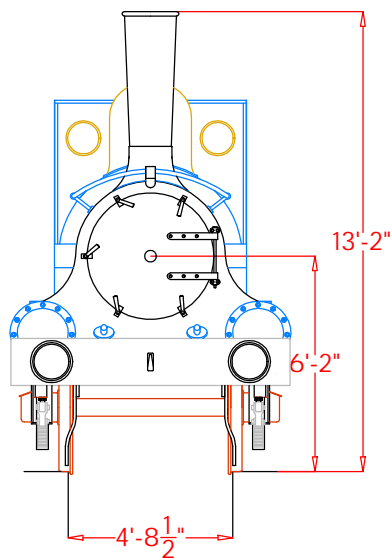

Caledonian Railway 2-4-0 and Tender of 1860
Beyer Peacock Order Numbers 415 & 416