

Front View

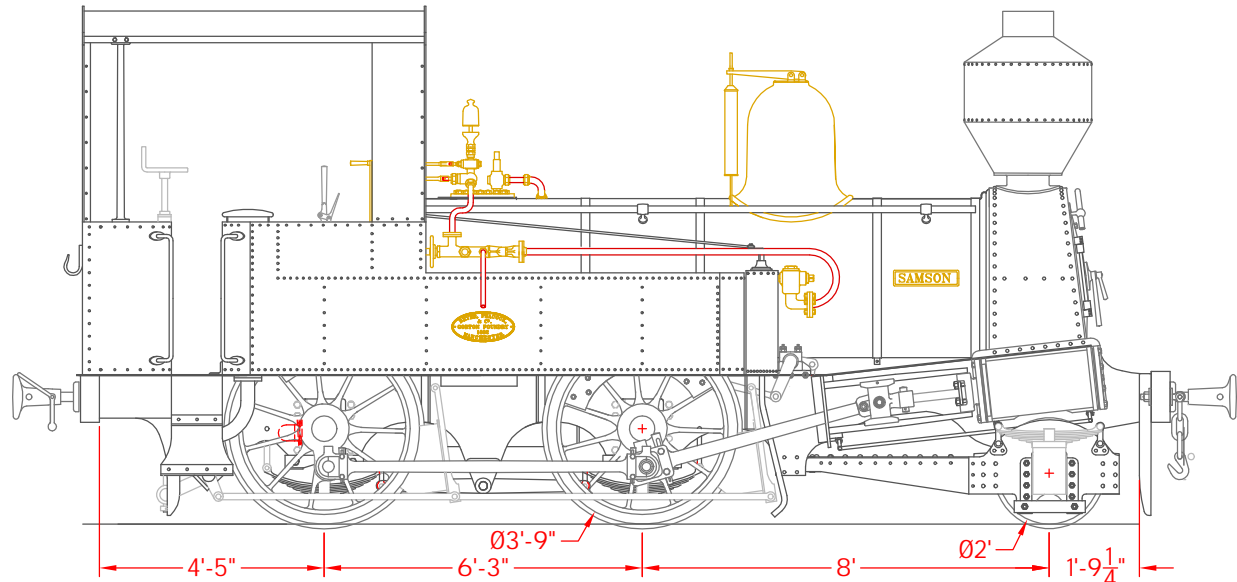

Right Hand Side Elevation

Building Details

Engine	Order No.	Date	Qty.	Builders Nos.	Customer
Samson	6191	1882	1	2158	McLean Brothers & Rigg (West Australia)
Samson No.2	7211	1889	1	3120	McLean Brothers & Rigg (West Australia)

Locomotive Data from Beyer Peacock book :- "General Dimensions of Engines in Service"

Cylinder Size	11" dia. x 18" stroke	Driving and Coupled Wheels	3' 9" dia.
Heating Surface		Boiler Pressure	120 p.s.i.
Tubes	376.48 Square Feet	Tank Capacity	300 gals.
Firebox	40.00 Square Feet	Weight (Working Order)	
Total	416.48 Square Feet	Engine	16 tons 19 cwt.

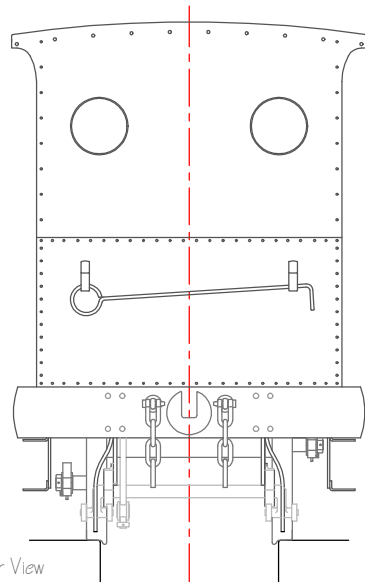

Rear View



Beyer Peacock 2-4-0 Side Tanks (Order Nos. 6191 & 7211)  
 Purchased by McLean & Rigg 1882 & 1889 (3'-6"ga.)