

Locomotive Data

Cylinder Size 14 1/2" x 20" str.

Dr. Wheels 3' 3" dia

Pony & Bogie Wheels 2' 00"

Allen Straight Link Valve Gear

Boiler Pressure 160 psi

Heating Surface

Tubes 641 Sq. Ft.

Firebox 57.5 Sq. Ft.

Total 698.7 Sq. Ft.

Locomotive Weight 36tons Ocwt 2qrts.

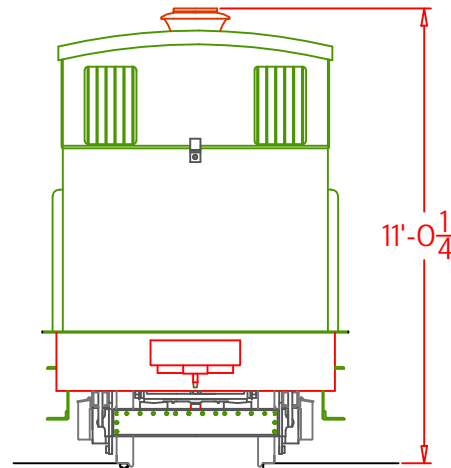
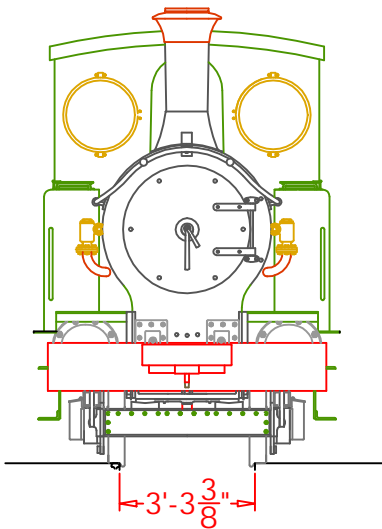

2-6-4 Tank Engine built by Beyer Peacock, Manchester for the Malta Railway.

First Order No. 7943 of 1895.  
Builders No. 3678  
Malta Railways No.7

Second Order No. 8071 of 1896.  
Builders No. 3852  
Malta Railways No.8

Third Order No. 8531 of 1900.  
Builders No. 4163  
Malta Railways No.9

Fourth Order No. 9373 of 1905.  
Builders No. 4719  
Malta Railways No.10

